

Bosch Motorsport BR540 High Flow In Tank Fuel Pump



Brand: Bosch Motorsport

Product Code: BOSBR540

Availability: In Stock

Weight: 0.60kg

Dimensions: 10.00cm x 5.00cm x 5.00cm

Price: \$385.00

Short Description

Specifically released by Bosch Motorsport (FPx-HF, F 02U V0U 343-01) and ONLY available direct or through Bosch Motorsport stockists

Highest flowing Bosch in-tank fuel pump available! Flows 460L/hr at 2.75bar (40psi) and an amazing 270L/hr at 10bar (145psi).

Description

Highest flowing Bosch in-tank fuel pump available!!

- Up to 540 l/h @ open flow
- Up to 460 l/h @ 40Psi (2.75bar)
- Up to 380 l/h @ 80Psi (5.5bar)
- An amazing 270l/h @ 145Psi (10.0bar)
- High flow all the way up to the 190Psi (13.0bar) Pressure Relief Valve setting
- 9.0mm (nom.) barbed outlet fitting suits rubber or nylon hose
- Light weight (550g) and Compact 46mm body size
- Includes electrical connector with wires
- Includes High flow filter

- Draws ~16A @ 40Psi (2.75bar), ~19A @ 80Psi (5.5bar), ~24A @ 145Psi (10.0bar)

NOTE: This pump needs to be securely installed inside the fuel tank via hanger or similar. Care should be taken to prevent separation of the filter from the pump. This pump has been released by Bosch Motorsport only for motorsport/offroad applications.

Specifications

- Up to 460 l/h @ 40Psi (2.75bar)
- Up to 380 l/h @ 80Psi (5.5bar)
- An amazing 270l/h @ 145Psi (10.0bar)
- High flow all the way up to the 190Psi (13.0bar) Pressure Relief Valve setting
- 9.0mm (nom.) barbed outlet fitting suits rubber or nylon hose
- Light weight (550g) and Compact 46mm body size
- Includes electrical connector with wires
- Includes High flow filter
- Draws ~16A @ 40Psi (2.75bar), ~19A @ 80Psi (5.5bar), ~24A @ 145Psi (10.0bar)

Characteristic Data

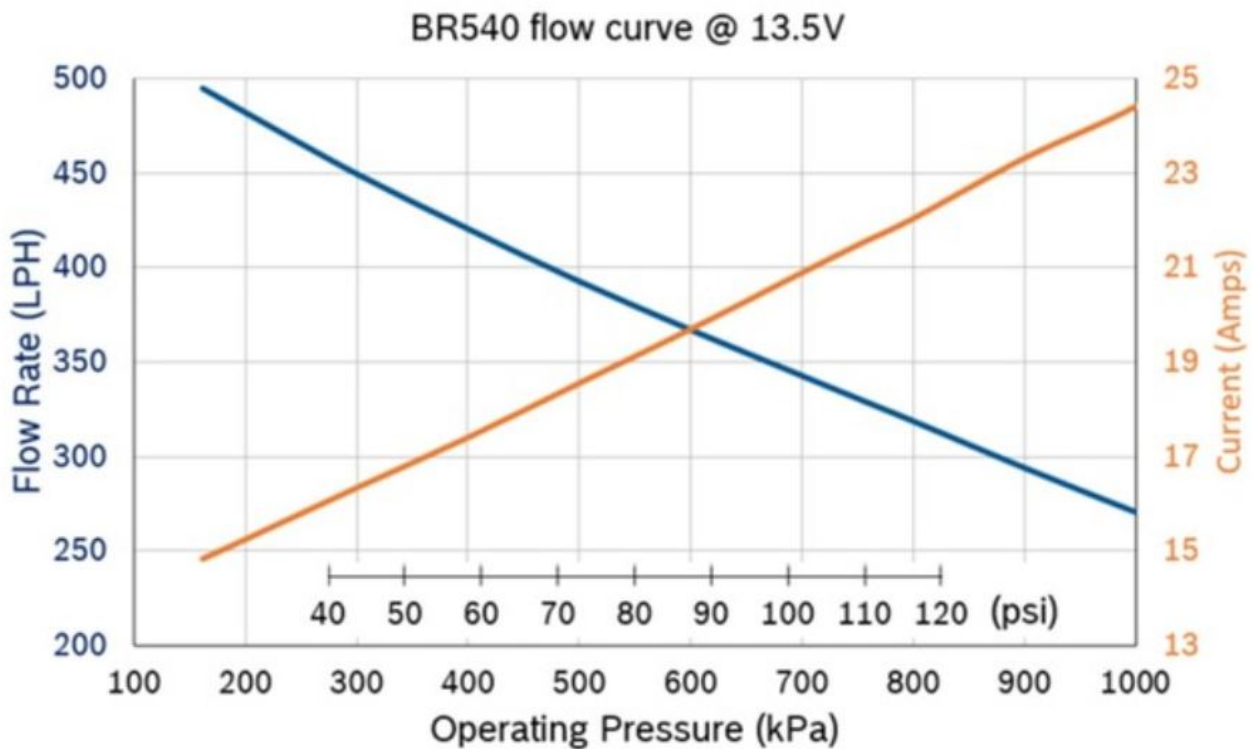

Dimensions

Dimensions

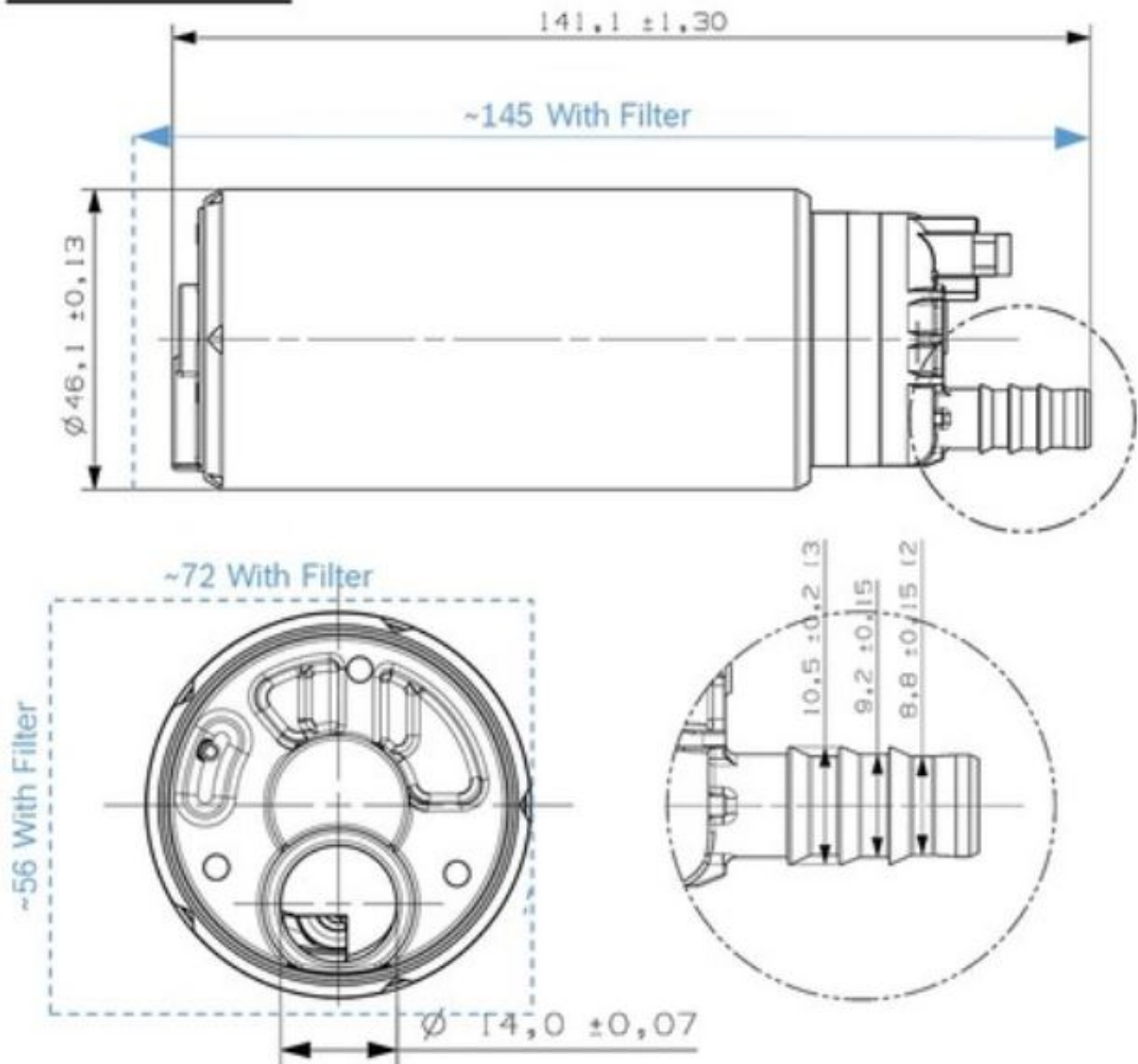

Electrical

- This pump can draw in excess of 24 amps. High quality wire of the correct size must be used.
- Connector included in kit

Pinout

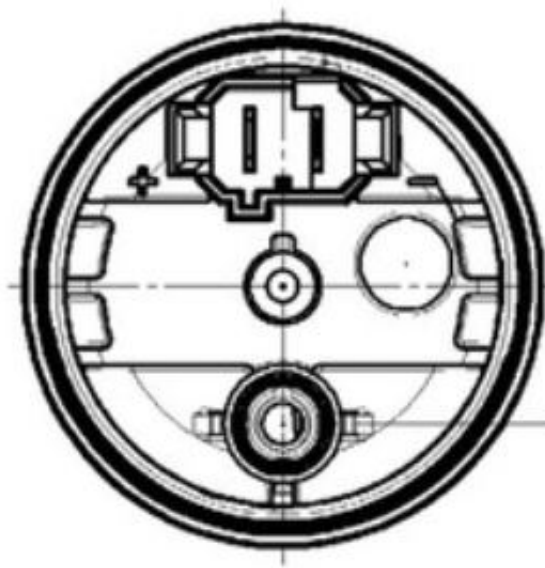

Product Gallery



FPx-HF - In tank Fuel Pump (BR540) (F 02U V0U 343-01)



- Up to 540 l/h open flow
- Very high flow at high pressure
- Light weight at only 550g
- Compact 48 mm body diameter
- 5.0mm flat pin connector
- 9 mm (nom.) bedded outlet fitting
- 13 bar (190 psi) Pressure Relief Valve
- Electrical connector with wires included
- High flow filter included
- Improved OES tolerance through internal design and materials

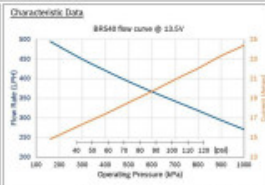
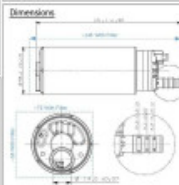

Installation Notes
 Operating Voltage: 4 to 15V | Secure attachment of filter must be assured
 Requires secure mounting inside fuel tank

This in-tank pump kit is specifically released by Bosch Motorsport (FPx-HF, F 02U V0U 343-01) for OffroadMotorsport use only. It is **ONLY** available direct or through Bosch Motorsport stockists.